



2022 AGM Presentation

Critical Minerals Group Limited (**ASX:CMG, Critical Minerals Group, CMG** or the **Company**) provides the Company's 2022 presentation for today's Annual General Meeting.

This announcement was approved by the board.

For more information:

Scott Dreincourt

Managing Director

info@criticalmineralsgroup.com.au

(07) 5555 5055

About Critical Minerals Group Limited

Critical Minerals Group Limited (**ASX:CMG, CMG** or the **Company**) is an exploration company with the principle focus of developing critical minerals projects. CMG was formed to identify, secure, acquire and develop critical mineral resource tenements in proven regions in Australia.

CMG is building its position in the vanadium market, holding a tenement in north-west Queensland near the town of Julia Creek which is its flagship project known as the Lindfield Vanadium Project. CMG also holds tenements for projects at Figtree Creek and Lorena Surrounds, both exciting greenfield copper-gold projects that support CMG's focus on critical mineral opportunities. CMG has also applied for three tenements within close proximity to the Lindfield Vanadium Project, forming its Whinmoor Project, Lara Downs Project and Lindfield North Project.

CMG is founded on the outlook of the global energy disruption and the transition that is currently underway and the chance to grasp the opportunities arising from the substantial changes in the world around us. The rising standard of living of a growing global population is likely to continue to drive demand for critical minerals for years to come, particularly during the phase of decarbonisation and electrification. The world will need to find a way to meet this growing demand for such minerals, and CMG is well-positioned to meet this new economy mineral demand as the world turns towards a more renewable future.

For personal use only

ersonal use only



CRITICAL MINERALS GROUP

A N N U A L
G E N E R A L
M E E T I N G

NOVEMBER 2022



Critical Minerals Group Limited ACN 652 994 726 (CMG or the company) is the issuer of this presentation. The issue of this presentation is intended only for the person or entity it has been transmitted.

Securities Disclaimer

This presentation is for informational purposes only and does not constitute an offer to sell, or solicit to purchase, any securities.

Limited Responsibility for Information

This presentation contains forward-looking statements. Those forward-looking statements reflect views held only as at the date of this presentation. Any such statements is subject to inherent risks and uncertainties. Actual events or results may differ materially from the events or results expressed or implied in any forward looking statements, and such deviations are both normal and to be expected. Recipients must make their own assessment about the likelihood of a matter, about which a forward looking statement is made, occurring. CMG makes no representation about the likelihood of a matter, about which a forward looking statement is made, occurring. CMG and its directors, employees, agents, advisers and consultants give no representation or warranty to a recipient of this presentation as to the accuracy or completeness of the statements contained in this presentation or in relation to any other matter; and to the full extent permitted by law, disclaim responsibility for and have no liability to a recipient of this presentation for any error or omission in or for any statement in this presentation.

Reliance on Presentation

A recipient of this presentation must make their own assessment of the matters contained herein and rely on their own investigations and judgment in making an investment in CMG. This presentation does not purport to contain all of the information a recipient of this

presentation may require to make an informed decision whether to invest in CMG. Specifically, this presentation does not purport to contain all the information that investors and their professional advisers would reasonably require to make an informed assessment of CMG's assets and liabilities, financial position and performance, profits, losses and prospects.

No Recommendation

The information in this presentation is not a recommendation to acquire shares and does not constitute financial advice. Any person who intends to acquire shares must conduct their own investigations, assessment and analysis of CMG and its operations and prospects and must base their investment decision solely on those investigations and that assessment and analysis. Prospective investors should consult their own legal, accounting and financial advisers about an investment in CMG.

Competent Persons Statement

The information in this presentation that relates to the exploration results, exploration targets and mineral resources at the Lindfield Project (EPM 27872), Figtree Creek Project (EPM 27998) and Lorena Surrounds Project (EPM 27999) was first reported by CMG in its prospectus dated 25 May 2022 (**Prospectus**). CMG confirms that it is not aware of any new information or data that materially affects the information included in the Prospectus, and that all material assumptions and technical parameters underpinning the exploration results, exploration targets and mineral resources in the Prospectus continue to apply and have not materially changed.

The information in this presentation that relates to the exploration results, exploration targets and mineral resources at the Whinmoor Project (EPM 28631 application), Lara Downs Project (EPM 28635

application) and Lindfield North Project (EPM 28636 application) was first reported by CMG in its announcement dated 19 October 2022. CMG confirms that it is not aware of any new information or data that materially affects the information included in the announcement date 19 October 2022, and that all material assumptions and technical parameters underpinning the exploration results, exploration targets and mineral resources in the announcement continue to apply and have not materially changed.

Announcements

This presentation should also be read in conjunction with CMG's Prospectus, the CMG Annual Report for 2022 and the CMG September 2022 Quarterly Activities Report, together with any announcement made by CMG in accordance with its continuous disclosure obligations including but not limited to the following ASX releases:

- 27 September 2022 – CMG – Commencement of Trading
- 12 October 2022 – Commencement of Drilling at Lindfield Vanadium Project
- 19 October 2022 – New Tenement Applications
- 27 October 2022 – Company Presentation – October 2022
- 28 October 2022 – Figtree Creek and Lorena Surrounds Tenements Granted
- 2 November 2022 – Completion of drilling at Lindfield Vanadium Project.

ersonal use only

We're meeting the growing demand for minerals critical to ensuring a carbon neutral future.

Our ESG Vision

Corporate Snapshot

Vanadium Development in a premium jurisdiction

Total Share on Issue	44.08M
Options (@ \$0.25)	8.36M
Cash	\$4M
Market Capitalisation (undiluted)	\$9.25M
Share Price (08/11/22)	\$0.21

Major Shareholders

Top 20	79.7%
Idemitsu Lindfield	32.22%
Founders, Management & Board	27.9%



Significant Shallow JORC resource¹

210Mt @ 0.39% V₂O₅
Inferred JORC resource,
from surface.



Established mining region in Julia Creek QLD

Supported by existing
infrastructure, road, rail,
power & port.



Significant government incentives

Government policy
creating investment
tailwinds for critical
minerals.



Project development underway²

24 hole drill program
completed October 2022
with metallurgical studies
commencing Q4 2022.

1. Refer to CMG's prospectus dated 25 May 2022 (**Prospectus**). The information in this presentation that relates to the mineral resource estimates for CMG's Lindfield Project (EPM 27872) was first reported by CMG in its Prospectus. CMG confirms that it is not aware of any new information or data that materially affects the information included in the Prospectus, and in the case of estimates of mineral resources, that all material assumptions and technical parameters underpinning the estimates in the Prospectus continue to apply and have not materially changed.

2. Refer to CMG's ASX announcements dated 12 October 2022 and 2 November 2022.

Board & Management



Alan Broome. AM
Chairman

- Extensive Mining & Board experience
- NED of DDH1 (ASX: DDH)
- Emeritus Chairman of Austmine
- Chairman of Strategic Minerals Plc (AIM: SML.L)
- Advisory Council to the CSIRO's Mineral Resources Sector
- Chairman of New Age Exploration (ASX: NAE)
- Awarded the Order of Australia (AM) for services to mining



Scott Drelincourt
Managing Director

- Geologist and Founding Director
- Proven executive with 16 years industry experience
- 6 years experience working on Julia Creek Vanadium projects
- Extensive resources experience from Greenfields exploration and early stage development through to mining operations



Art Malone
Non-Exec Director

- Senior Energy and Resources Executive.
- 15 years managing large scale projects in the resource sector.
- Director of CopperCorp Pty Ltd an unlisted Cloncurry Copper Gold exploration project.
- Managing Director of Peak Helium



Toni Myers
Company Secretary

- Toni is an experienced corporate lawyer drawing on over 12 years of practice within the legal industry. Toni has held a broad range of roles from private practice (both in top tier and boutique firms) through to government and inhouse roles.
- Toni has aided companies by advising on and assisting with various Corps Act, Listing Rules and regulatory compliance for multiple junior exploration companies.

ersonal use only

Lindfield Inferred JORC

VANADIUM PROJECT^{1,2}

The Lindfield Vanadium resource is our flagship project, ready to develop and meet the growing demand for this critical mineral.

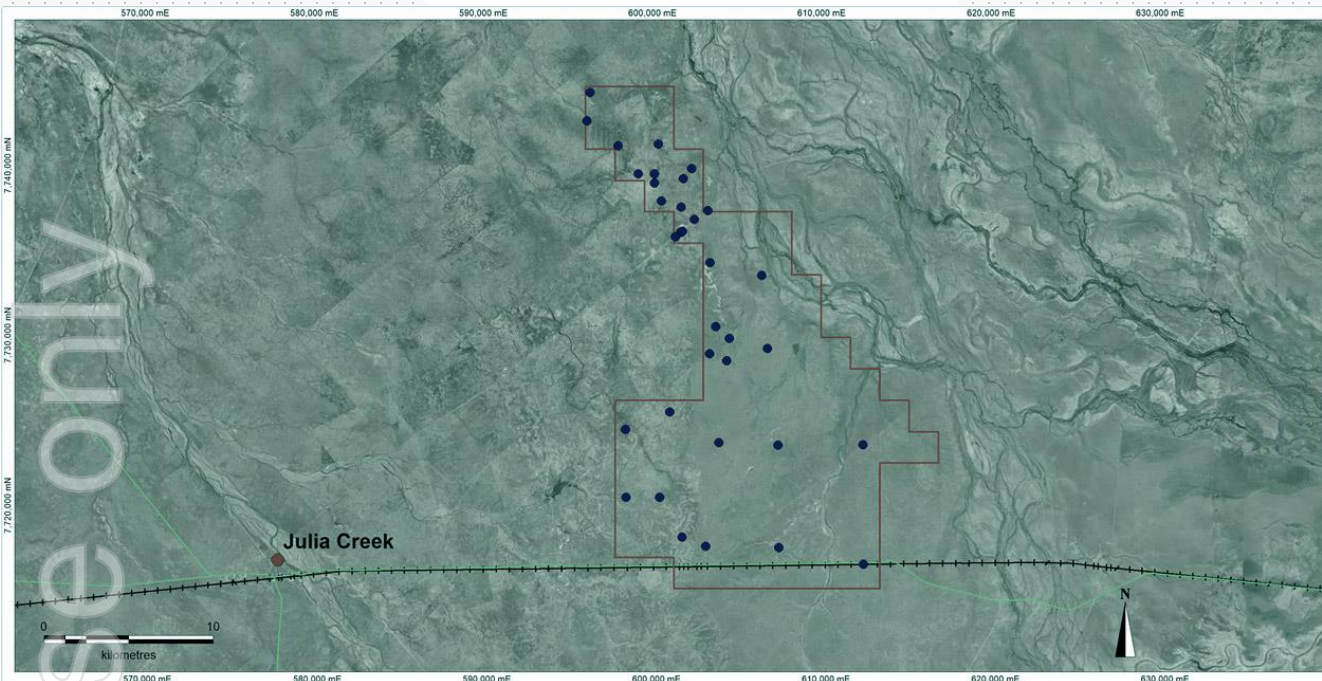

Inferred JORC

Inferred JORC resource of 210Mt with a grade of 0.39% V₂O₅ from surface. The site has 68 drill holes within the tenement, with a resource upgrade underway.

1. Refer to CMG's prospectus dated 25 May 2022 (**Prospectus**). The information in this presentation that relates to the mineral resource estimates for CMG's Lindfield Project (EPM 27872) was first reported by CMG in its Prospectus. CMG confirms that it is not aware of any new information or data that materially affects the information included in the Prospectus, and in the case of estimates of mineral resources, that all material assumptions and technical parameters underpinning the estimates in the Prospectus continue to apply and have not materially changed.
2. Refer to CMG's ASX announcements dated 12 October 2022 and 2 November 2022.



Shallow

Shallow resource starting at surface, down to a depth of approximately 35 meters.



Potential HPA & Mo

Additional potential minerals; High Purity Aluminum and Molybdenum. The recent drill program and test work aim to identify any potential additional resources.



Limited Contaminants

Limited contaminants (for batteries) such as titanium from hard rock deposits likely lowering processing costs.

Location & Infrastructure

295km² tenement in the North West Mineral Province of Queensland located 30km from Julia Creek.

Surrounded by advanced vanadium projects including Multicom Resources' St Elmo Project (Mining Lease) and Richmond Vanadium Technology's Lilyvale Project.

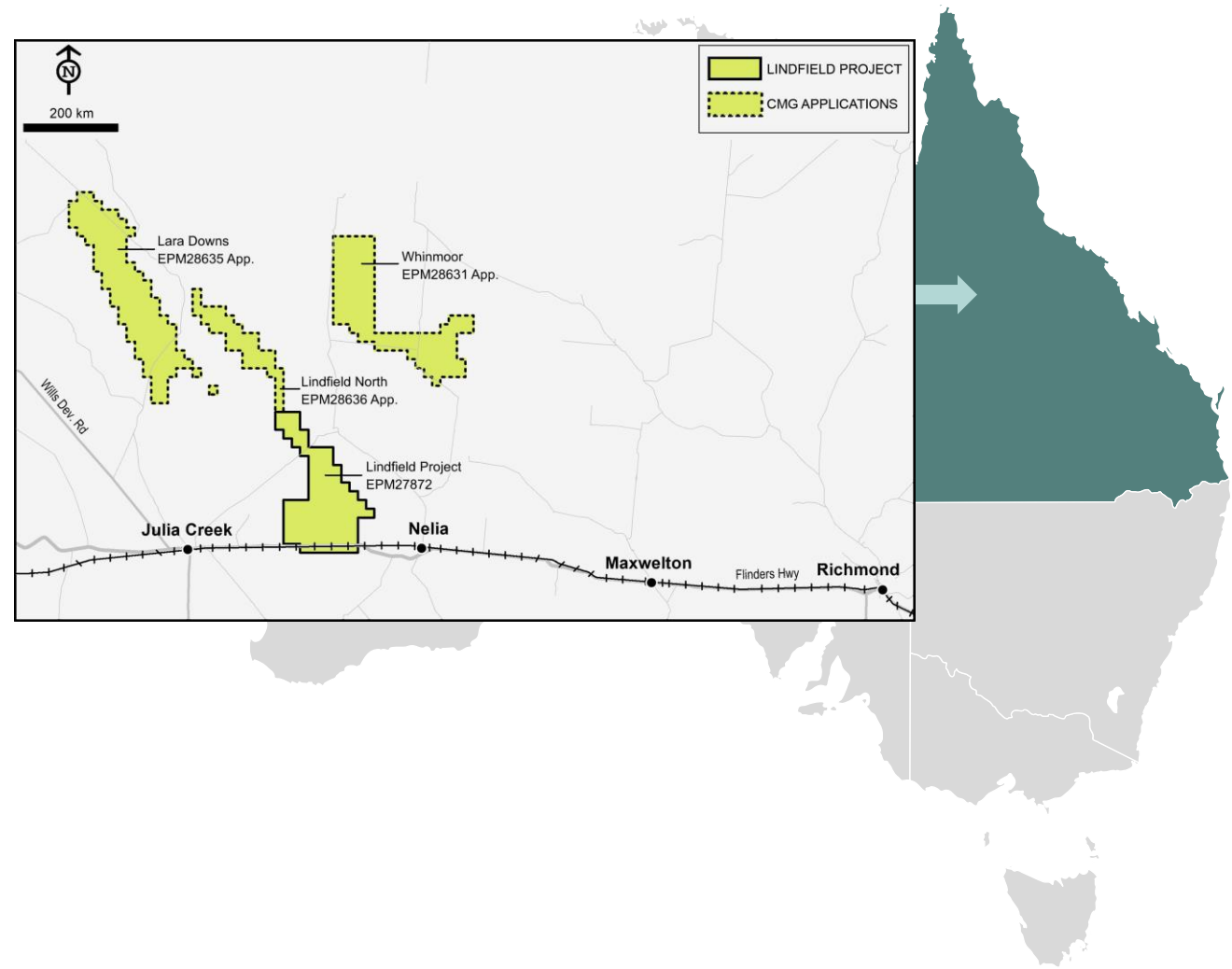

Power

Mains grid access for power

Rail & Roads

Intersected by rail system and Flinders Hwy

Water

Available surface water

Port

Abbot Point terminal 650km via road and rail

ersonal use only

Unique Deposit Shale Based From Surface

- Ore is soft and at surface requiring no drill and blasting or milling
- Depth advantage = low strip ratio and amenable to standard open cut mining
- Geology gives the deposit an advantage for beneficiation allowing for higher V2O5 concentrate upgrade through floatation separation
- This gives oxidized shallow vanadium deposits a significant advantage over titanomagnetite deposits (hard rock). Resulting in less complex processing, reducing the overall CAPEX and OPEX.

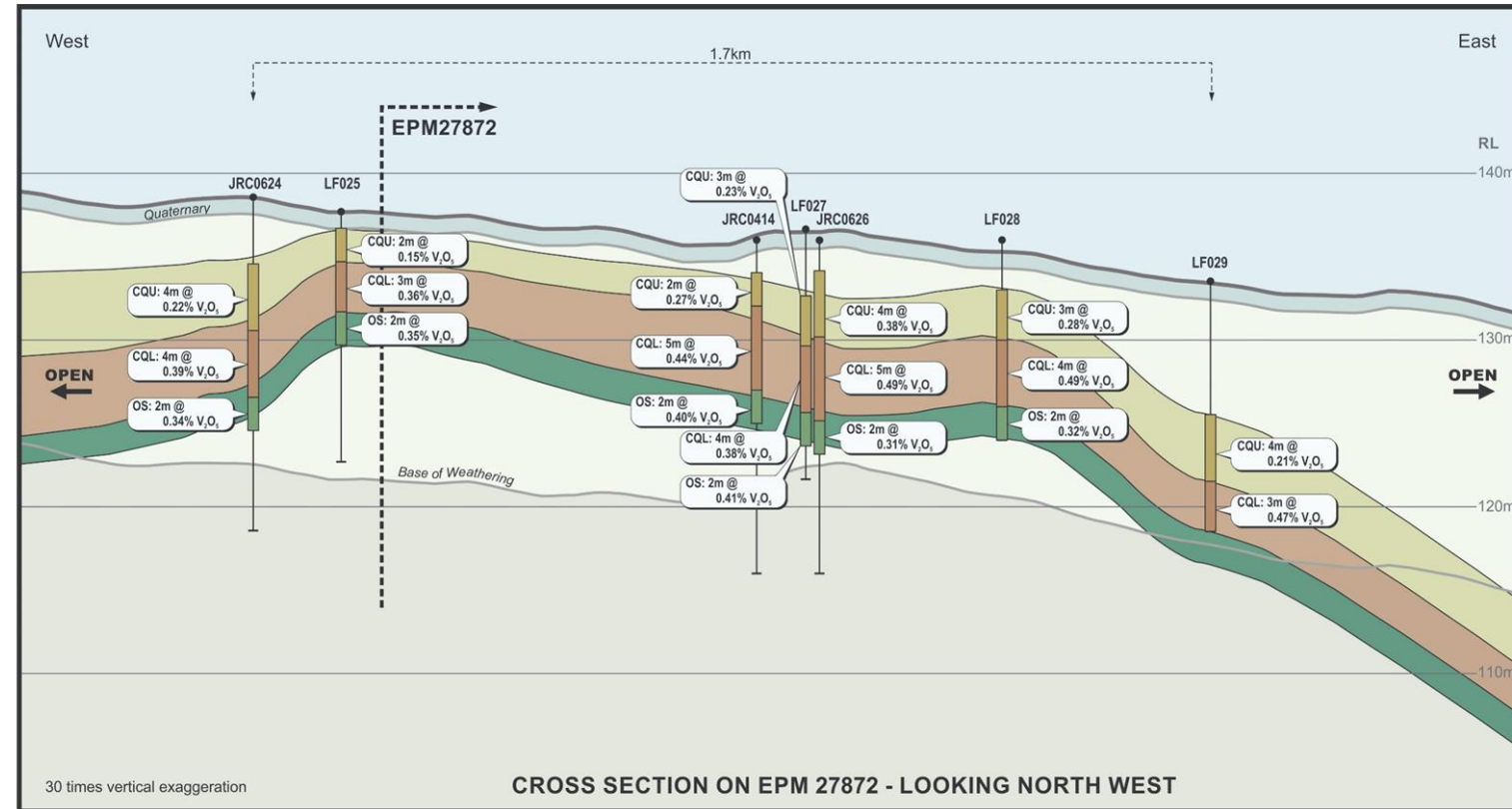

Vanadium Redox Flow Batteries

- ▶ VRFB's are poised to play a significant role as a large-scale, long-duration energy storage solution
- ▶ Superior life of approximately 30 years
- ▶ Can hold charge for long periods
- ▶ No flammable, explosion or toxicity risk, and batteries do not deteriorate
- ▶ Highly recyclable/reusable
- ▶ VRFB manufacturers are actively seeking supply unsuccessfully
- ▶ Largest VRFB located in Dalian China with 100MW/400MWH to be scaled up to 800MWH. Holds 9000 tonnes of V₂O₅

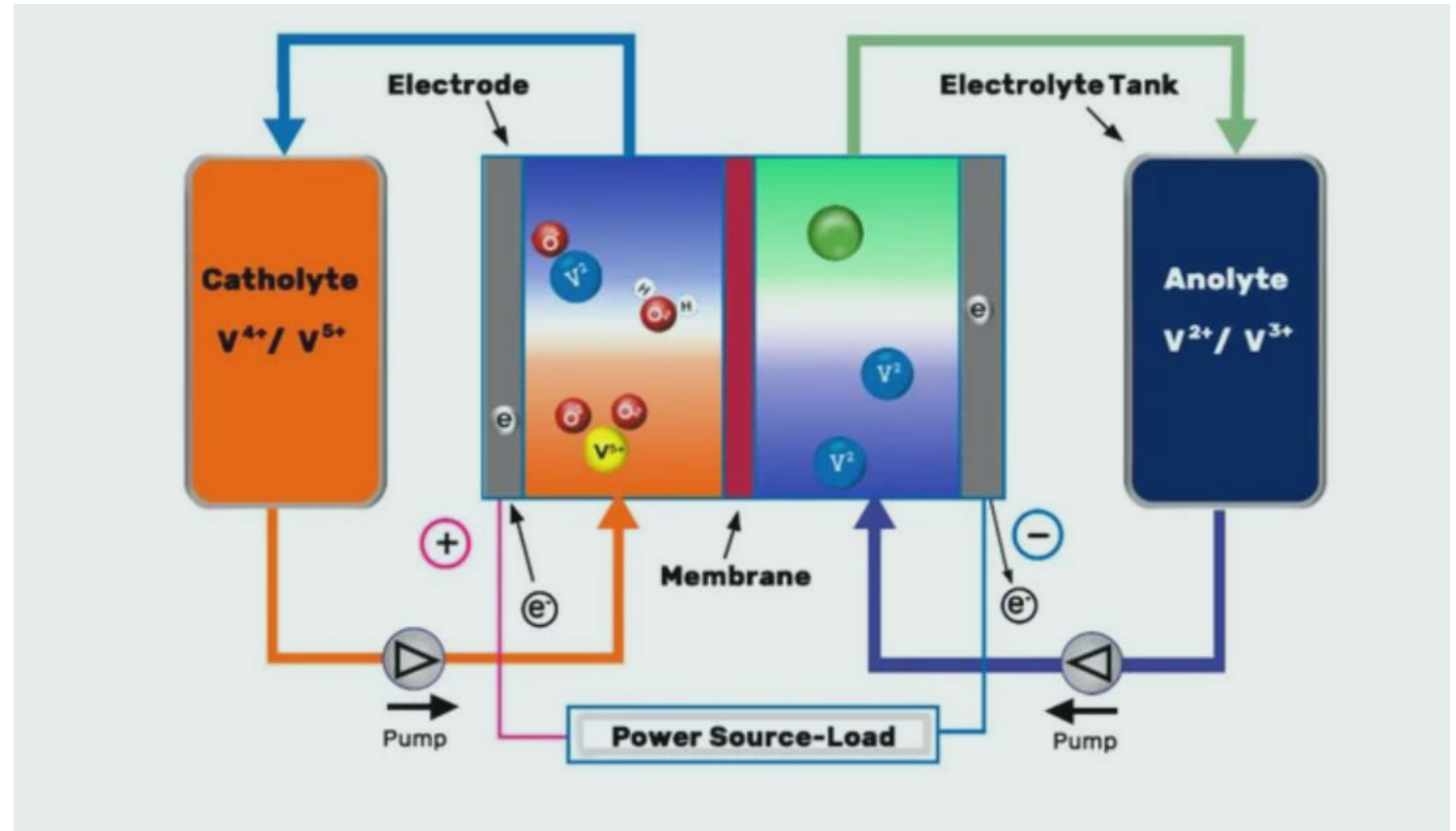
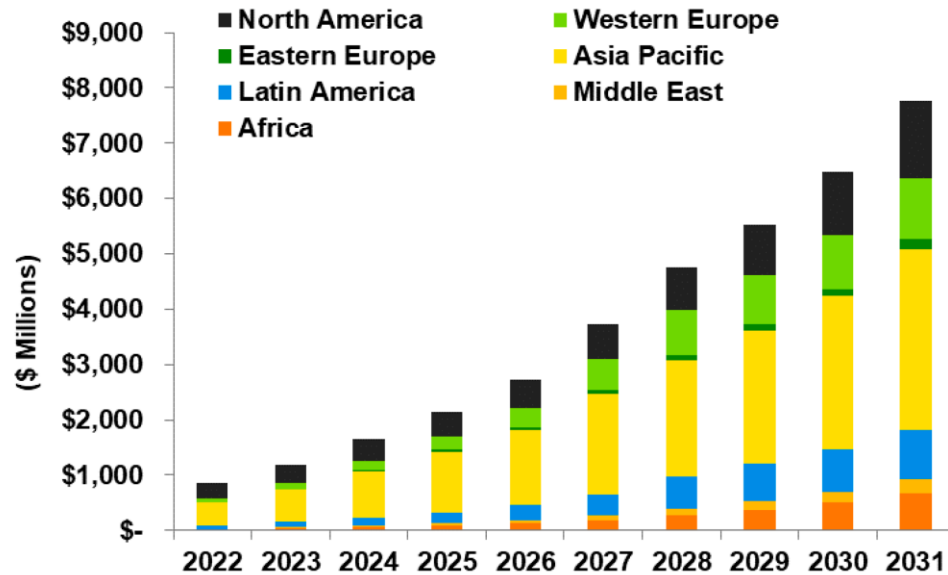

Figure 1: Schematic illustration of a VRFB. Source: Encyclopedia Journal (ISSN 2309-3366)

Vanadium Supply & Demand

Annual Installed VRFB Utility-Scale and Commercial and Industrial Deployment Revenue by Region, All Application Segments, World Markets: 2022-2031



(Source: Guidehouse Insights)

Annual Installed VRFB Utility-Scale and Commercial and Industrial Battery Deployment Energy Capacity by Region, All Application Segments, World Markets: 2022-2031

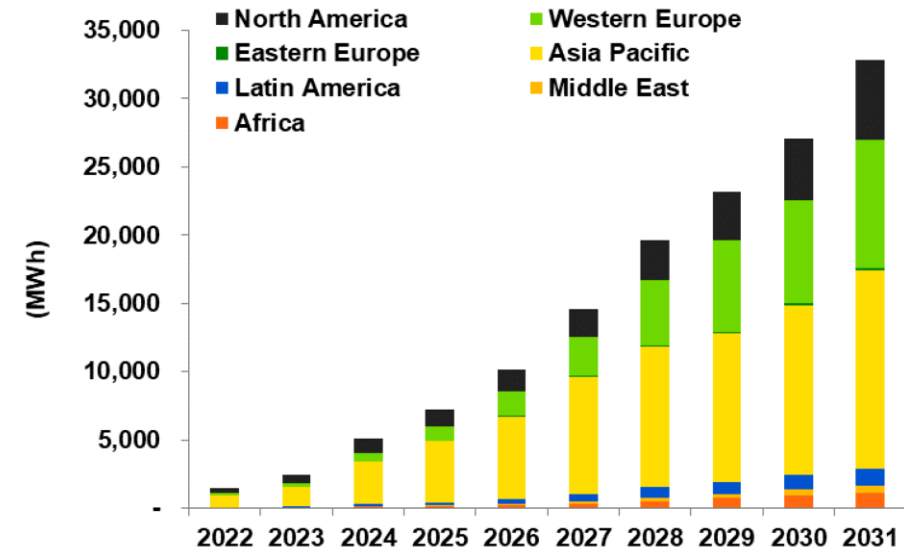

(Source: Guidehouse Insights)

- ▶ Vanadium consumption in batteries is forecast to grow at an average compound rate of 41% per year from 2022 to 2031.

Source: Guidehouse Insights: White Paper Vanadium Redox Flow Batteries Identifying Market Opportunities and Enablers Published 2Q 2022

Disclaimer: A recipient of this presentation must make their own assessment of the matters contained herein and rely on their own investigations and judgment.

Vanadium Tailwinds & Development Strategy

Vanadium Processing Pilot Plant

\$1.265m grant (Federal Gov) to Brisbane Met Labs

[Click here for more Info](#)



Battery Manufacturing Queensland

\$100m Federal government commitment to develop battery manufacturing in QLD

[Click here for more info](#)

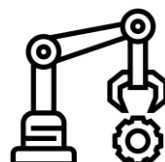

CMG is leveraging off the significant grants and incentives put in place to develop domestic production of Vanadium, particularly for use in Vanadium Redox Flow Batteries as a grid scale energy solution

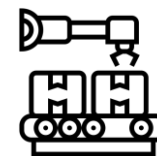

Vanadium Demonstration Plant

\$10m Fully funded (QLD Gov) to build plant in Townsville

[Click here for more info](#)



National Battery Testing Centre (NBTC)

\$50m project and \$15m funded (QLD Gov) . NBTC will look at Vanadium flow battery development & standards. Critical Minerals Group is working with NBTC to supply vanadium battery precursor material.

[Click here for more info](#)



Progress So Far

- **Flagship granted (2021)**
- refer to CMG's prospectus dated 25 May 2022
- **Flagship JORC (2021)**
- refer to CMG's prospectus dated 25 May 2022
- **Prospectus lodged (2022)**
- refer to CMG's prospectus dated 25 May 2022
- **Secured Idemitsu Australia as a Strategic Investor (2022)**
- refer to CMG's ASX announcement dated 27 September 2022
- **Listed on ASX (Sept 27th 2022)**
- **Commenced drilling at Flagship (2022)**
- refer to CMG's ASX announcement dated 12 October 2022
- **New tenement applications around flagship (2022)**
- refer to CMG's ASX announcement dated 19 October 2022
- **Granting of Cu/Au tenements (2022)**
- refer to CMG's ASX announcement dated 28 October 2022
- **Completed drilling at flagship (2022) (23 x 4 inch core holes, 1x open hole and 3x water monitoring holes)**
- refer to CMG's ASX announcement dated 2 November 2022

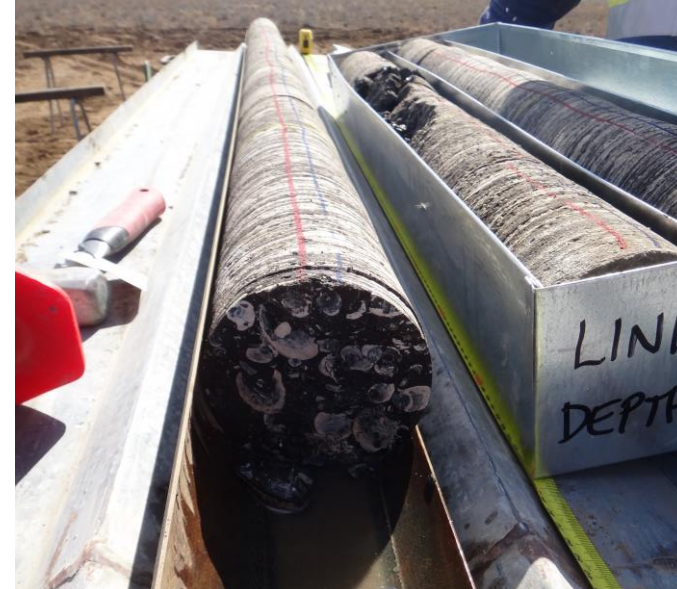

Lindfield Exploration



Toolebuc Formation Outcrop (oxidized) at The Lindfield Project



Oxidized Core from The Lindfield Project 2022

ersonal use only

Newly Granted Tenements

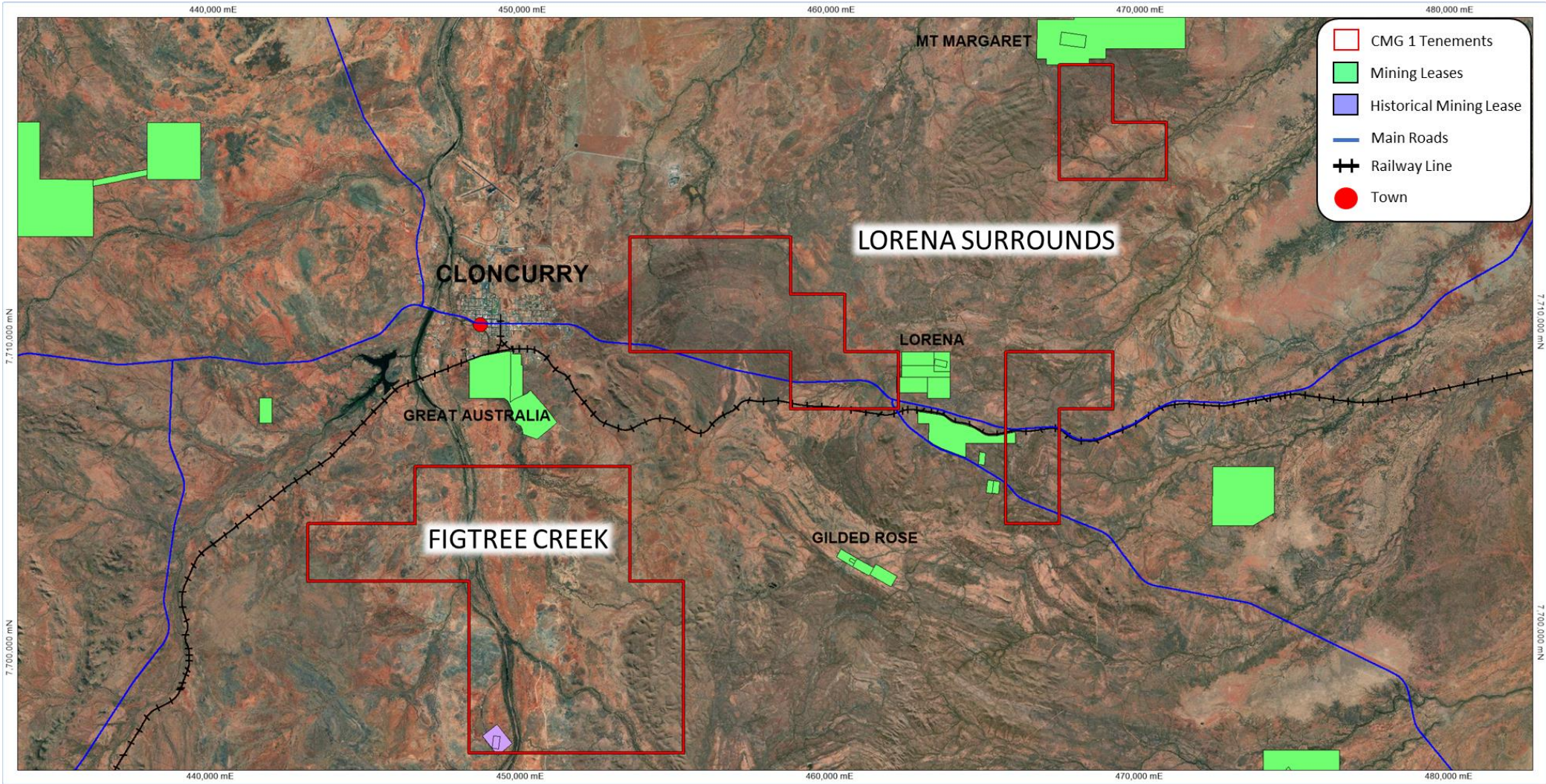

Source: Queensland Government, GeoResGlobe, Available at: <https://georesglobe.information.qld.gov.au/>

ersonal use only

Where to Next

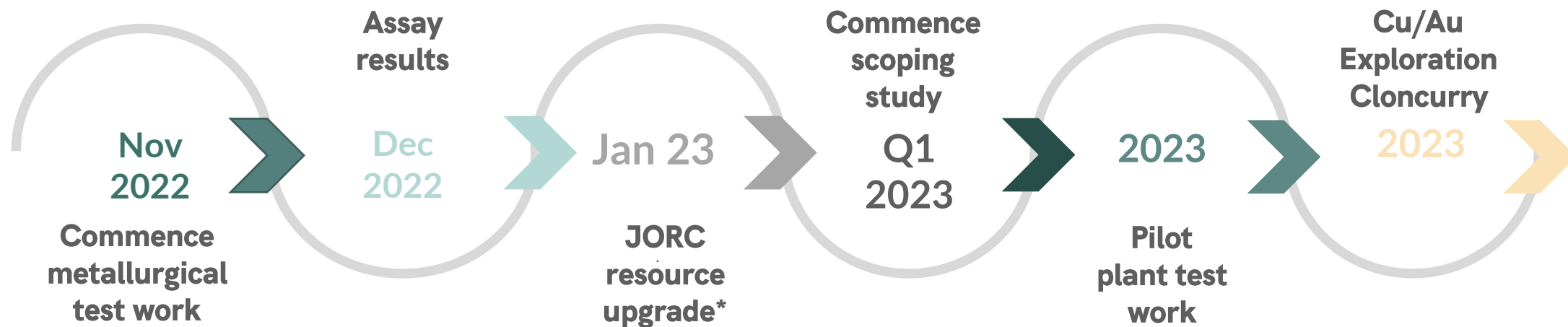

*Subject to drilling results.

Key Contacts



Critical Minerals Group Ltd

Managing Director
Scott Drelincourt

info@criticalmineralsgroup.com.au
(07) 55 555 055
criticalmineralsgroup.com.au

Media and IR

NWR Communications
Peter Taylor

Email: peter@nwrcommunications.com.au
Tel: 0412 036 231
nwrcommunications.com.au